

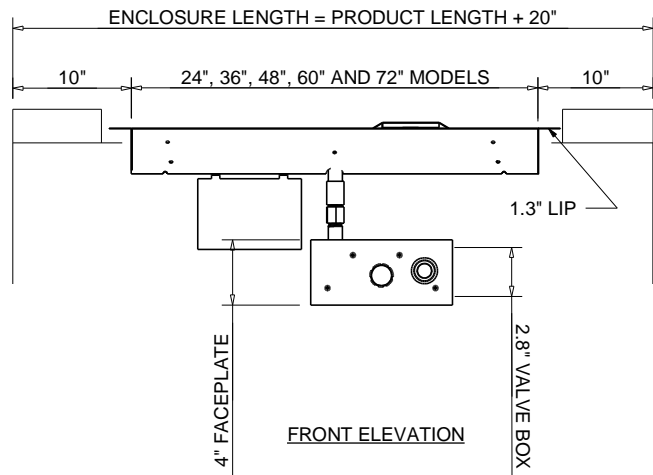

Hearth Products Controls Co
CSA CERTIFIED-OUTDOOR USE ONLY

HEARTH PRODUCTS CONTROLS
 3050 PLAINFIELD RD.
 KETTERING, OH 45432
 TOLL FREE: 1-877-433-7001
 PHONE: (937) 433-7000
 FAX: (937) 433-0704
 www.hpcfire.com

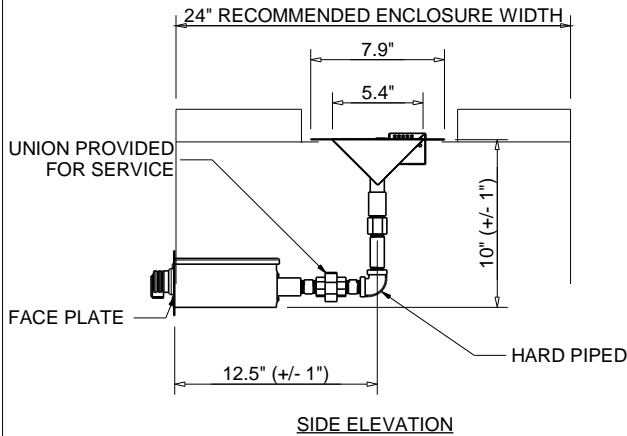

SPARK IGNITION BY AA BATTERY

PART NUMBERS	STND BTU
FPPK24-TRGH	50K
FPPK36-TRGH	75K
FPPK48-TRGH	90K
FPPK60-TRGH	90K
FPPK72-TRGH	140K

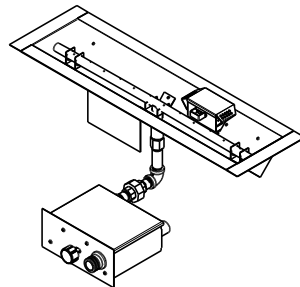

ISOMETRIC VIEW

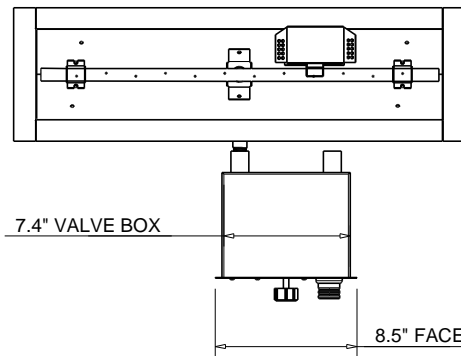

PLAN VIEW

Notes:

1. FOR USE WITH FIXED PIPING SYSTEMS ONLY.
2. NOT FOR USE WITH SMALL TANKS.
3. ALL ENCLOSURES REQUIRE 2 each 18 SQ/IN VENTS ON OPPOSING SIDES AND ADEQUATE DRAINAGE.
4. RESIDENTIAL GAS PRESSURE ONLY. (NG- 7.0" WC, LP- 11.0" WC)
5. MODIFICATION OF PRODUCT WILL VOID ANY CERTIFICATION AND WARRANTY.
6. FOLLOW ALL MANUFACTURER INSTALLATION INSTRUCTIONS AND LOCAL CODES.
7. ALL DIMENSIONS ARE CONSIDERED TRUE AND REFLECT MANUFACTURER'S SPECIFICATIONS AS OF THE REVISION DATE.
8. DO NOT SCALE DRAWING.
9. THESE DRAWINGS ARE FOR SIZING AND PLANNING PURPOSES. ALL INFORMATION CONTAINED HEREIN WAS CURRENT AT THE TIME OF DEVELOPMENT. THE MANUFACTURE IS RESPONSIBLE FOR THE ACCURACY OF THE DRAWING.
10. CONTRACTOR'S NOTE: FOR PRODUCT AND COMPANY INFORMATION VISIT www.CADdetails.com/info REFERENCE NUMBER 771-005.

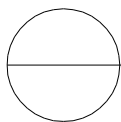

FPPK FIRE PIT INSERT
 FPPK LINEAR TROUGH - FLAME SENSING WITH SPARK IGNITION